



1118  
BAGGAGE CART

**WORLD CARTE®**



**Worthy of today's world-class airports; engineered by the world's most experienced cart operator.**

Smarte Carte's new Worldcarte® baggage cart is attractive, functional and durable. Its ergonomic design allows travelers to comfortably move bags of all shapes and sizes through your airport. When not in use the carts nest closely to require minimal floor space.

Our carts not only streamline the flow of traffic through and out of your airport, they give travelers control of their belongings and the mobility to visit airport shops and

restaurants. Smarte Carte® baggage carts are an integral part of a traveler's passage through your airport.

Smarte Carte's Worldcarte baggage carts are rented from cart management units strategically placed in high demand areas of your airport. With the ongoing attention and maintenance of your cart service by an on-site team of Smarte Carte professionals, you can be sure a cart is always available for every traveler who needs one.

***smartecarte***®

1-800-838-1176  
[www.smartecarte.com](http://www.smartecarte.com)

# 1118 BAGGAGE CART WORLDCARTE®

- Sleek, lightweight design makes carts easy to maneuver.
- Three-wheel design provides smooth, quiet movement over all surfaces.
- Durable stainless steel construction offers maximum corrosion resistance.
- Non-marring wheels and front roller bumpers protect airport property.
- Carts nest tightly to require minimal floor space.
- When nested, carts have a turning radius of 9 feet, allowing easy, efficient movement around the airport.
- Wire basket holds briefcase, lap top or small bag.
- Cart does not have any accessible or hidden cavities.
- Large two-sided rear advertising panel and side panels provide additional revenue source.



Smarte Carte's cart advertising program provides an additional revenue source for your airport. Large ad space is attractive to advertisers.

## SPECIFICATIONS

Cart Height:	38.4 inches
Length:	41.1 inches
Width:	26 inches
Weight:	40 pounds
Basket:	4 inches high x 18 inches wide x 7 inches deep
Advertising Panel:	3/16" thick ABS Panel size: 18.4 inches x 13.25 inches
Casters/wheels:	6-inch diameter swivel caster 8-inch diameter rear wheels
Frame:	1 inch tubular stainless steel, with TIG welds and an electropolish finish.
Nesting:	10.5 inches
Performance:	Cart will not tip when placed on 10 degree slope in any position with 40 lbs. placed in basket area.  Cart will not tip or allow items to fall off platform while transitioning a 6-inch curb.
Options:	<ul style="list-style-type: none"> <li>• dual-wheel front caster</li> <li>• compatible with Smarte Carte cart management units</li> </ul>

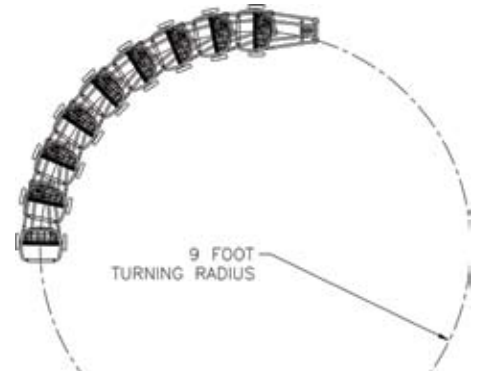

Carts have turning radius of 9 feet when nested, providing superior maneuverability when moving large numbers of carts with electric tugs.

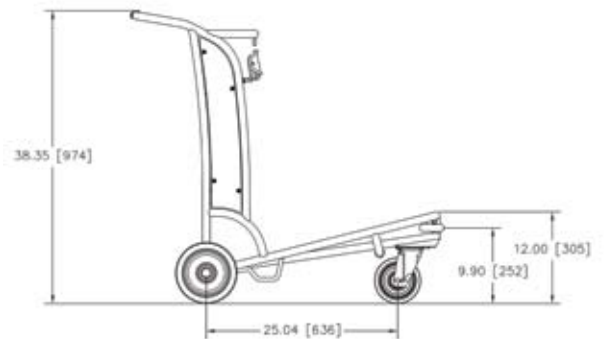

**smartecarte®**

1-800-838-1176

www.smartecarte.com

4455 White Bear Parkway  
Saint Paul, Minnesota 55110-7641 USA